

# INDUSTRIAL REFLECTORS FOR DISCHARGE LAMPS

Explosion Proof Electrical Equipment



Weatherproof Lighting

KRONOS SAT

**Installation:** safe area  
**Insulation class:** I

## KRONOS SAT



	INDUSTRIAL REFLECTORS
	CEI / EN
EXECUTION	WEATHERPROOF
AMBIENT TEMPERATURE	-
PROTECTION DEGREE	IP65
CERTIFICATE REF.	-
RULES OF COMPLIANCE	EN 60598-1 + A1; EN 60598-2-5

### Mechanical characteristics

Housing	die-casting aluminium complete with stainless steel safety chains
Diffuser	plane tempered glass resistant to shocks and thermal shocks, coupled with stainless steel clips and secured with a security chain
Painting	thermosetting polyester powder resistant to atmospheric agents and corrosion
Reflector	anodized and polished 99,85 pure aluminum
Cable entry	cable gland M20 IP68 tear proof

### Electrical characteristics

Power supply	conventional ballst 230V - 50Hz p.f. corrected (cos $\rho \geq 0,95$ )
Lampholders	ceramic E27 / E40
Internal wiring	1,5mm/sq silicon cables with glass sheat

### ON REQUEST ACCESSORIES:

- Galvanized steel wire protection guard
- Electronic device for aux halogen lamp
- Control gear with voltage supply different than standard

## KRONOS SAT Technical data

CODE	LAMP TYPE	TEMPERATURE CLASS (GAS)	TEMPERATURE CLASS (DUSTS)	LAMPHOLDER	CABLE GLAND	DETAIL
<b>INDUSTRIAL REFLECTORS FOR MERCURY VAPOUR LAMPS - POWER SUPPLY 230V-50Hz</b>						
KRONOS-125MBF	125 W	-	-	E-27	M20	A
KRONOS-250MBF	250 W	-	-	E-40	M20	A
KRONOS-400MBF	400 W	-	-	E-40	M20	A
<b>INDUSTRIAL REFLECTORS FOR METAL HALIDE LAMPS - POWER SUPPLY 230V-50Hz</b>						
KRONOS-150JM	150 W	-	-	E-27	M20	A
KRONOS-250JM	250 W	-	-	E-40	M20	A
KRONOS-400JM	400 W	-	-	E-40	M20	A
<b>INDUSTRIAL REFLECTORS FOR HIGH PRESSURE SODIUM LAMPS - POWER SUPPLY 230V-50Hz</b>						
KRONOS-150SAP	150 W	-	-	E-40	M20	A
KRONOS-250SAP	250 W	-	-	E-40	M20	A
KRONOS-400SAP	400 W	-	-	E-41	M20	A

## KRONOS SAT Technical features

CODE	A [mm]	B [mm]	ØC [mm]	ØD [mm]	WEIGHT [Kg]	CABLE GLAND	DETAIL
KRONOS-125MBF	535	265	550	295	4,62	M20	A
KRONOS-250MBF	535	265	550	295	5,03	M20	A
KRONOS-400MBF	535	265	550	295	6,35	M20	A
KRONOS-150JM	535	265	550	295	5,22	M20	A
KRONOS-250JM	535	265	550	295	5,17	M20	A
KRONOS-400JM	535	265	550	295	6,50	M20	A
KRONOS-150SAP	535	265	550	295	5,22	M20	A
KRONOS-250SAP	535	265	550	295	6,57	M20	A
KRONOS-400SAP	535	265	550	295	7,76	M20	A

## Reference details

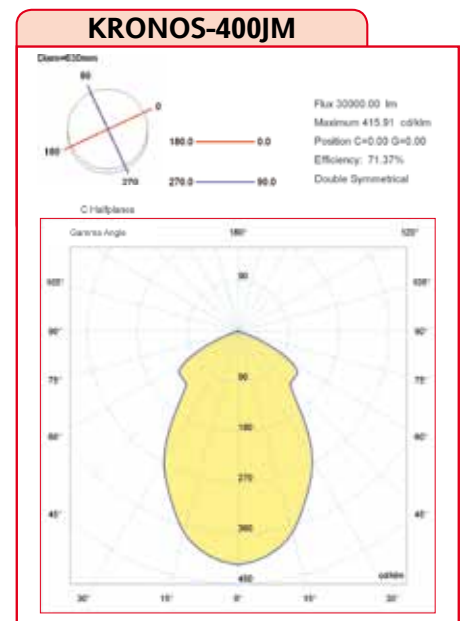
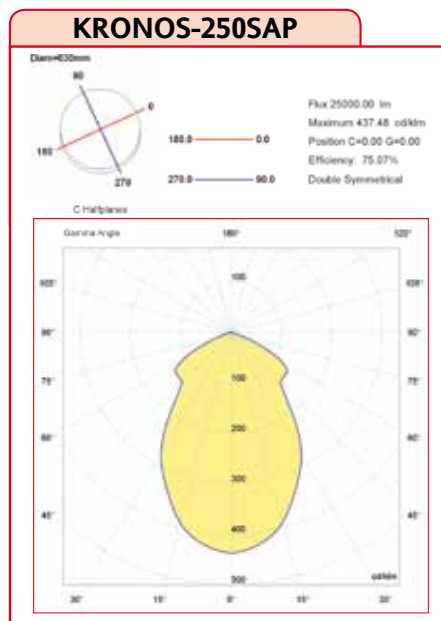
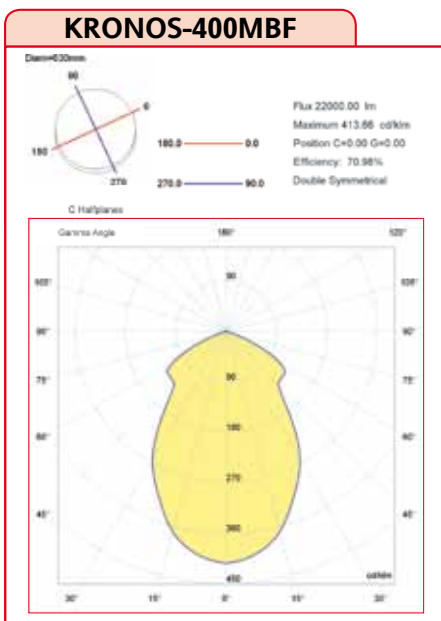
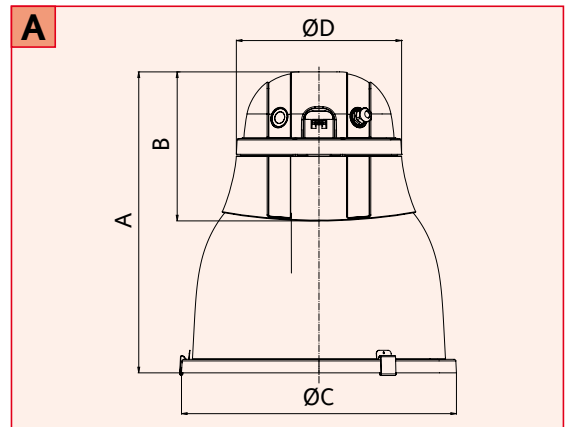

## KRONOS SAT On request accessories

CODE	DESCRIPTION	MATERIAL
930000.480	PROTECTION GRID Ø480	GALVANIZED STEEL
CLA	ELECTRONIC SWITCHING DEVICE FOR AUXILIARY LAMP	-

**REMARK:** Due to the development of the national and international specifications and of the technology, the above technical characteristics showed on this bulletin can be considered as binding on our confirmation only.