



**Installation:** hazardous areas - see below table  
**Classification:** see below table

## EJB UL



	<b>TERMINAL BOARD / POWER UNITS                      CONTROL AND SIGNALLING UNITS</b>
	<b>NEC - NEMA 4, 7, 9</b>
<b>INSTALLATION</b>	Class I - Groups B, C and D / Class II – Groups E, F, and G / Class III
<b>PROTECTION</b>	4, 7 BCD, 9 EFG
<b>AMBIENT TEMPERATURE</b>	-20°C ÷ +40°C
<b>MECHANICAL DEGREE</b>	IP66
<b>CERTIFICATION AND COMPLIANCES</b>	UL Standard 1203 - 4 <sup>th</sup> Ed. (15 Sett. 2006) Explosion-Proof / Dust-Ignition-Proof Electrical Equipment for Use in Hazardous (Classified) Locations

### Mechanical characteristics

Body and cover	marine grade copper free aluminium light alloy
Screws	stainless steel - internal / external
Internal plate	hot dip galvanized steel / aluminium
Fixing	galvanized steel stirrups th.10mm
Gaskets	O-RING silicon rubber on cover (option on request)

### ON REQUEST ACCESSORIES:

- External epoxy painting (any colours)
- Internal anticondensate painting orange RAL-2004
- O-Ring gaskets on cover
- Glass windows on cover
- Drain and breather valves
- Stainless steel hinges

## EJB UL Technical features

CODE	A [mm]	B [mm]	D [mm]	E [mm]	F [mm]	G [mm]	H [mm]	L [mm]	INT. PLATE X-Y [mm]	WEIGHT [Kg]	DETAIL
EJB-21UL	320	280	182	180	250	123	220	180	180 - 140	13,50	A
EJB-31UL	450	350	253	294	335	187	350	250	325 - 225	27,00	A
EJB-51UL	600	400	240	360	385	195	490	290	460 - 260	52,50	A
EJB-61UL	710	500	384	500	470	295	580	370	560 - 360	114,00	A
EJB-63UL	710	500	200	500	470	165	580	370	560 - 360	92,00	A

CODE	A [inch.]	B [inch.]	D [inch.]	E [inch.]	F [inch.]	G [inch.]	H [inch.]	L [inch.]	INT. PLATE X - Y [inch.]	WEIGHT [lbs]	DETAIL
EJB-21UL	12,60	11,10	7,20	7,10	9,90	4,90	8,70	7,10	7.10 - 5.60	31,00	A
EJB-31UL	17,80	13,80	10,00	11,60	13,20	7,40	13,80	9,90	12.80 - 8.90	62,00	A
EJB-51UL	23,70	15,80	9,50	14,20	15,20	7,70	19,30	11,50	18.20 - 10.30	121,00	A
EJB-61UL	28,00	19,70	15,20	19,70	18,60	11,70	22,90	14,60	22.10 - 14.20	262,00	A
EJB-63UL	28,00	19,70	7,90	19,70	18,60	6,50	22,90	14,60	22.10 - 14.20	212,00	A

### Reference details

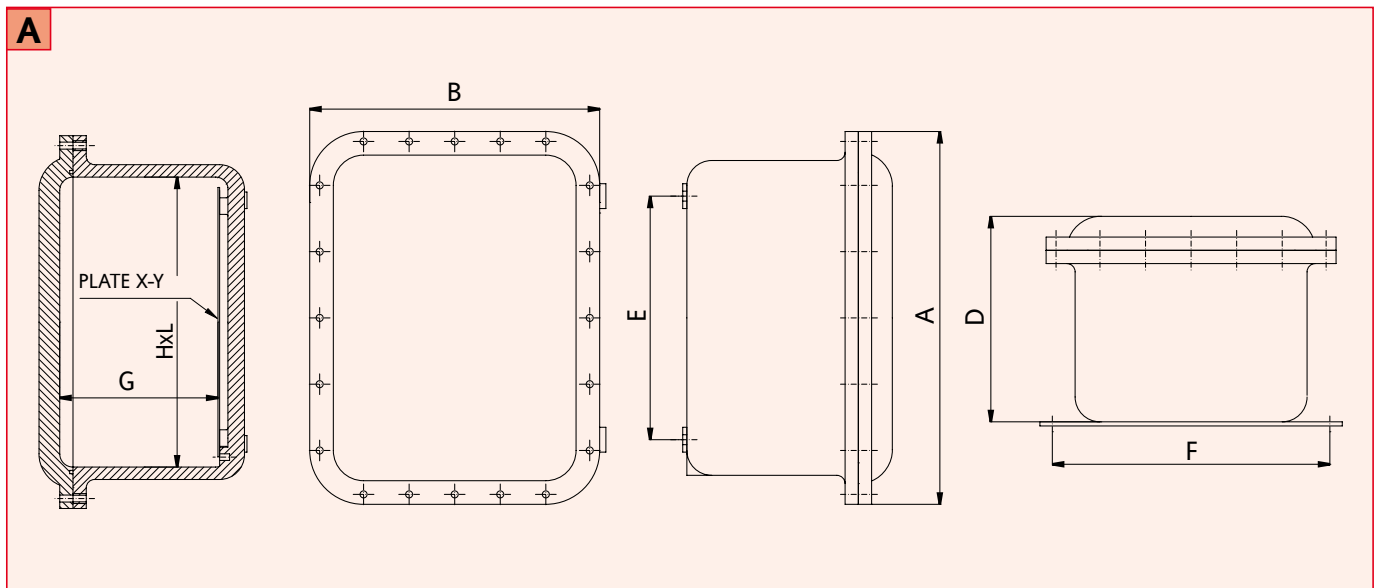

## EJB UL Body Enclosures Drilling Layout

ENCLOSURE CODE	AREA FOR ENTRY INSTALLATION (LONG WALL SIDES)				AREA FOR ENTRY INSTALLATION (SHORT WALL SIDES)			
	A [mm]	B [mm]	A [inch.]	B [inch.]	C [mm]	D [mm]	C [inch.]	D [inch.]
EJB-21 UL	190	80	7,50	3,20	150	80	6,00	3,20
EJB-31 UL	320	140	12,60	5,60	230	140	9,10	5,60
EJB-51 UL	450	120	17,80	4,80	250	120	9,90	4,80
EJB-61 UL	550	260	21,70	10,30	350	260	13,80	10,30
EJB-63 UL	550	150	21,70	6,00	350	150	13,80	6,00

## EJB UL Body Enclosures Drilling Layout

MINIMUM DISTANCE BETWEEN WALL ENTRIES (CENTER TO CENTER) 1st ROW [mm] - 2nd ROW [inch.]									
4" -	-	-	-	-	-	-	-	-	139 (5.47)
3" M90	-	-	-	-	-	-	-	115 (4.53)	126 (4.96)
2 1/2" M75	-	-	-	-	-	-	101 (3.98)	108 (4.25)	120 (4.72)
2" M63	-	-	-	-	-	88 (3.46)	94 (3.70)	102 (4.02)	112 (4.41)
1 1/2" M50	-	-	-	-	75 (2.95)	82 (3.23)	88 (3.46)	95 (3.74)	106 (4.17)
1 1/4" M40	-	-	-	67 (2.64)	70 (2.76)	77 (3.03)	84 (3.31)	91 (3.58)	103 (4.06)
1" M32	-	-	58 (2.28)	63 (2.48)	66 (2.60)	73 (2.87)	80 (3.15)	86 (3.39)	99 (3.90)
3/4" M25	-	52 (2.05)	55 (2.17)	59 (2.32)	63 (2.48)	69 (2.72)	79 (2.99)	83 (3.27)	95 (3.74)
1/2" M20	46 (1.81)	49 (1.93)	52 (2.05)	57 (2.24)	60 (2.36)	67 (2.64)	73 (2.87)	80 (3.15)	93 (3.66)
NPT Metric	1/2" M20	3/4" M25	1" M32	1 1/4" M40	1 1/2" M50	2" M63	2 1/2" M75	3" M90	4" -

### Reference details

#### WALL DRILLING AREA

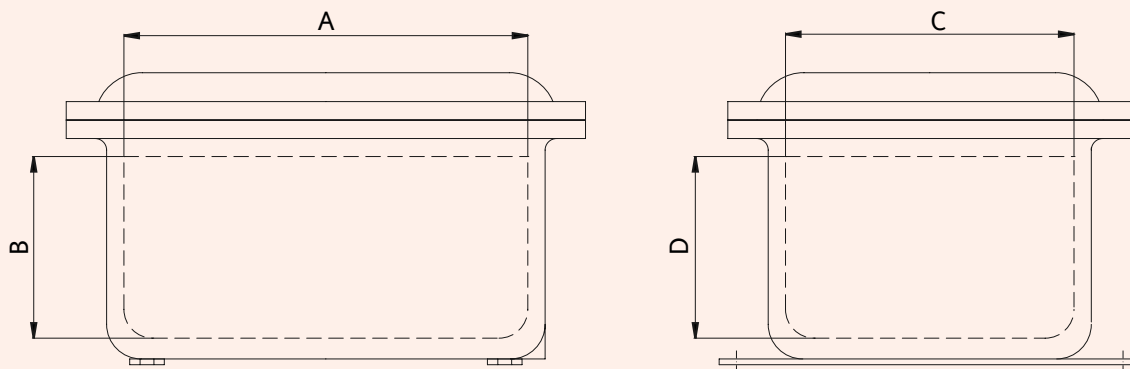

## EJB UL Cover Enclosures Drilling Layout

ENCLOSURE CODE	AREA FOR OPERATORS INSTALLATION ENCLOSURE COVER				MINIMUM DISTANCE BETWEEN OPENINGS (CENTER TO CENTER)	
	E [mm]	F [mm]	E [inch.]	F [inch.]	[mm]	[inch.]
EJB-21 UL	200	150	7,90	6,00	50	2,00
EJB-31 UL	300	200	11,90	7,90	50	2,00
EJB-51 UL	460	260	18,20	10,30	50	2,00
EJB-61 UL	570	370	22,50	14,60	50	2,00
EJB-63 UL	570	370	22,50	14,60	50	2,00

#### COVER DRILLING AREA

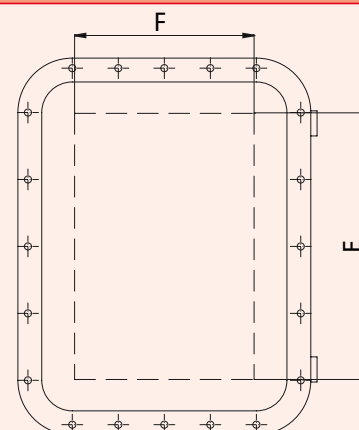

## EJB UL Indicative quantity of terminals and relevant section

CODE	SECT. 2,5 [mm/sq]	SECT.6,0 [mm/sq]	SECT. 10,0 [mm/sq]	SECT. 16,0 [mm/sq]	SECT. 35,0 [mm/sq]	SECT. 50,0 [mm/sq]	SECT. 70,0 [mm/sq]	SECT. 240,0 [mm/sq]	INT. PLATE X - Y	
									[mm]	[inch.]
EJB-21 UL	30 x 1	20 x 1	14 x 1	12 x 1	8 x 1	6 x 1	2 x 1	1 x 1	180 - 140	7.10 - 5.60
EJB-31UL	52 x 2	32 x 2	24 x 2	20 x 2	14 x 2	12 x 1	8 x 1	4 x 1	325 - 225	12.80 - 8.90
EJB-51 UL	80 x 2	46 x 2	36 x 2	30 x 2	22 x 2	18 x 2	16 x 1	6 x 1	460 - 260	18.20 - 10.30
EJB-61 UL	92 x 3	58 x 3	46 x 3	38 x 3	28 x 3	26 x 2	22 x 2	12 x 1	560 - 360	22.10 - 14.20
EJB-63 UL	92 x 3	58 x 3	46 x 3	38 x 3	28 x 3	26 x 2	22 x 2	12 x 1	560 - 360	22.10 - 14.20

### EJB UL Additional Technical features

#### PRODUCT COVERED

Explosion-proof enclosures for use in Hazardous Locations, Class I, Groups B, C, and D; Class II, Groups E, F, and G; Class III. These enclosures are Classified as to explosion and fire hazards only in according to Standard UL1203 4<sup>o</sup> ed.

The explosion-proof enclosures are suitable for Class I, Group B Hazardous Locations only when provided with from M20 to M90, 1/2 in. to 3 in., supply connection openings. If other supply connection openings are provided, then the enclosures are suitable for Class I, Groups C & D Hazardous Locations only. The 1/2 in. NPSM operator openings are only suitable for enclosures marked for Class I, Groups B, C & D Hazardous Locations

The enclosures covered by this Certification may have electrical components installed inside. The installation of electrical components shall not reduce the mechanical integrity of the enclosures.

The enclosures may or may not be provided with hinges for service of the enclosures only.

#### PROTECTION AGAINST CORROSION

All ferrous-metal other than stainless steel shall be protected against corrosion, except at joint surfaces and conduit threads There shall be no materials applied to joint surfaces.

#### GROUNDING

Internal Ground Screw – Hexagon head screw M6 x 10 with a stainless steel flat and lock washer provided on the base of the enclosure body.

External Ground – Terminal colored green, marked with the letter or word “G”, “GROUND”, or marked with a grounding symbol.

#### SUPPLY CONNECTIONS

NPT and Metric Supply Connections - The side walls of the enclosure are provided with conduit openings or none may be supplied, in which case field drilling and tapping instructions are provided with each enclosure. The entry is drilled and tapped completely through the enclosure wall, and the inside edge is smoothed and well-rounded such that the conductor insulation will not be damaged when installed. All unused openings are closed with plated steel, plated cast iron or aluminum close-up plugs which are threaded to match the opening. Closer-up Plugs have to be Listed for the same Class, Group and Division as marked on Enclosure nameplate.

#### OPERATOR OPENINGS

The cover of the enclosure may be provided with operator openings in the cover only and located only as given in drilling and tapping instructions provided with each Classified enclosure. All unused openings are closed with plated steel, plated cast iron or aluminum close-up plugs which are threaded to match the opening. Closer-up Plugs have to be Listed for the same Class, Group and Division as marked on Enclosure nameplate.

#### REMARK:

Due to the development of the national and international specifications and of the technology, the above technical characteristics showed on this bulletin can be considered as binding on our confirmation only.