

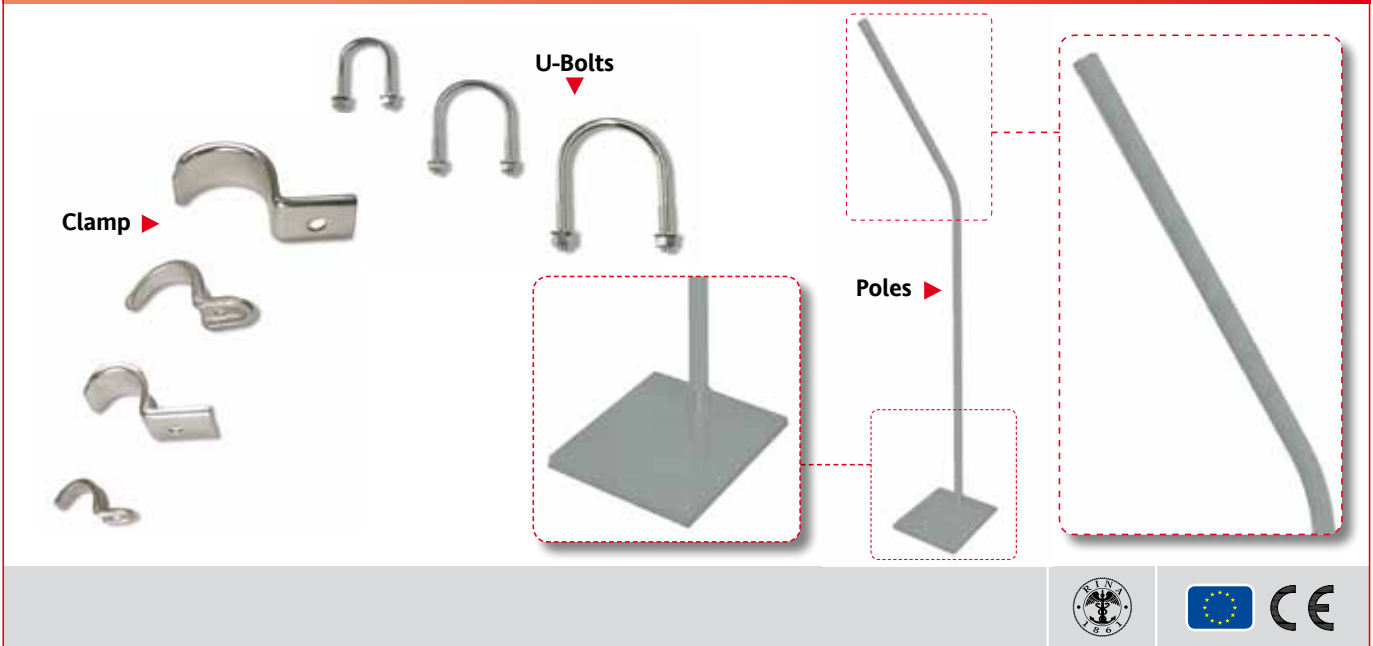

Installation: hazardous areas - Zone 1 / 2 (Gases)
Zone 21 / 22 (Dusts) - Safe Area

ACCESSORIES



POLES Technical features

CODE	A [mm]	B [mm]	ØC [mm]	ØD	R	MATERIAL	DETAIL
PAL041	1900	1650	1-1/2"	-	500	GALVANIZED STEEL	A
PAL042	500	1650	1-1/2"	-	500	GALVANIZED STEEL	A
PAL855	2700	1650	2-1/2"	1-1/2"	500	GALVANIZED STEEL	D
PAS043	700	-	1"	-	250	GALVANIZED STEEL	B
PAS856	3000	500	2-1/2"	1"	250	GALVANIZED STEEL	C
PAS857	2000	700	1-1/2"	1"	250	GALVANIZED STEEL	C

Other poles are supplied according to customer's request
Materials: stainless steel on request

Reference details

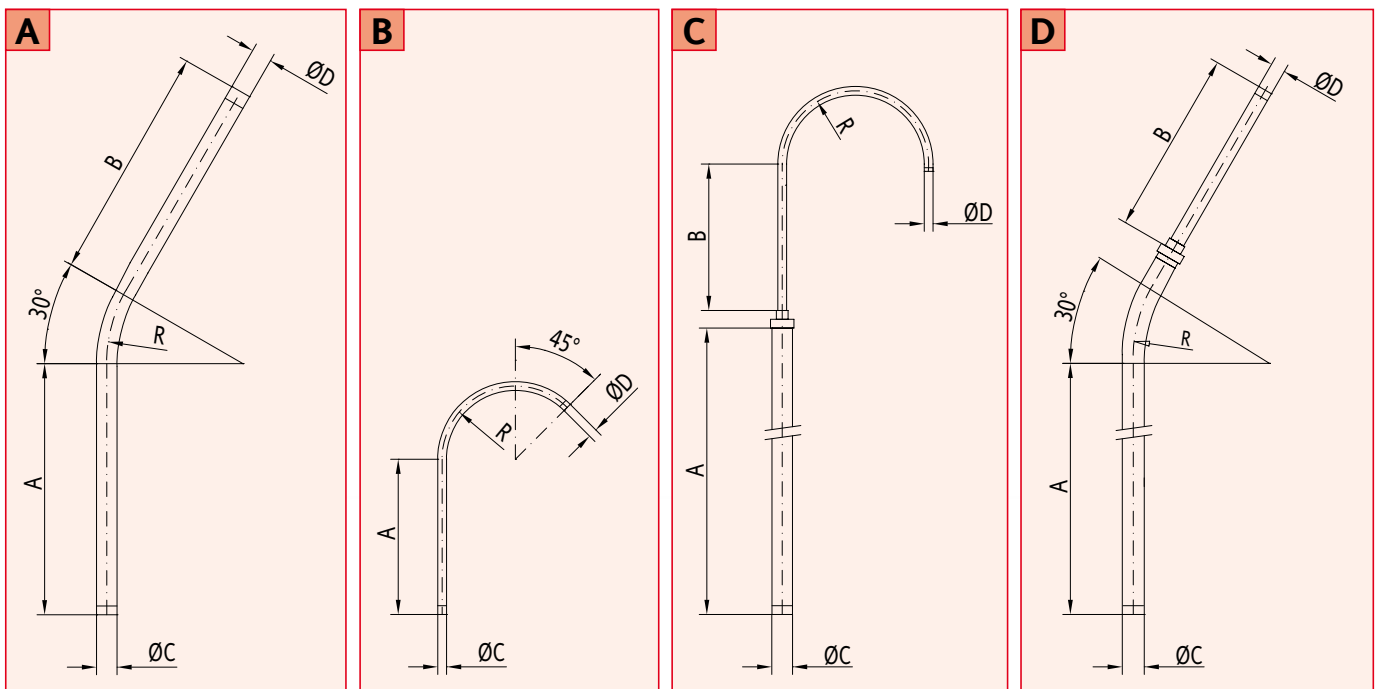

CLAMP Technical features

CODE	Ø CONDUIT	R	MATERIAL	DETAIL
GF1	1/2"	10	GALVANIZED STEEL	E
GF2	3/4"	12	GALVANIZED STEEL	E
GF3	1"	15	GALVANIZED STEEL	E
GF4	1-1/4"	20	GALVANIZED STEEL	E
GF5	1-1/2"	22,5	GALVANIZED STEEL	E
GF6	2"	27,5	GALVANIZED STEEL	E
GF7	2-1/2"	35	ALUMINUM	E
GF8	3"	45	ALUMINUM	E
GF10	4"	60	ALUMINUM	E

Reference details

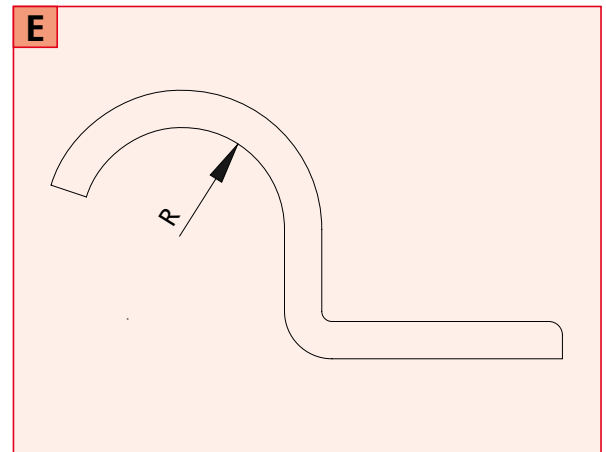

U-BOLTS Technical features

CODE	Ø CONDUIT	R	MATERIAL	DETAIL
GH1	1/2"	10	GALVANIZED STEEL	F
GH2	3/4"	12	GALVANIZED STEEL	F
GH3	1"	15	GALVANIZED STEEL	F
GH4	1-1/4"	20	GALVANIZED STEEL	F
GH5	1-1/2"	22,5	GALVANIZED STEEL	F
GH6	2"	27,5	GALVANIZED STEEL	F
GH7	2-1/2"	35	GALVANIZED STEEL	F
GH8	3"	45	GALVANIZED STEEL	F
GH10	4"	60	GALVANIZED STEEL	F

With nuts and washer
Materials: stainless steel on request

Reference details

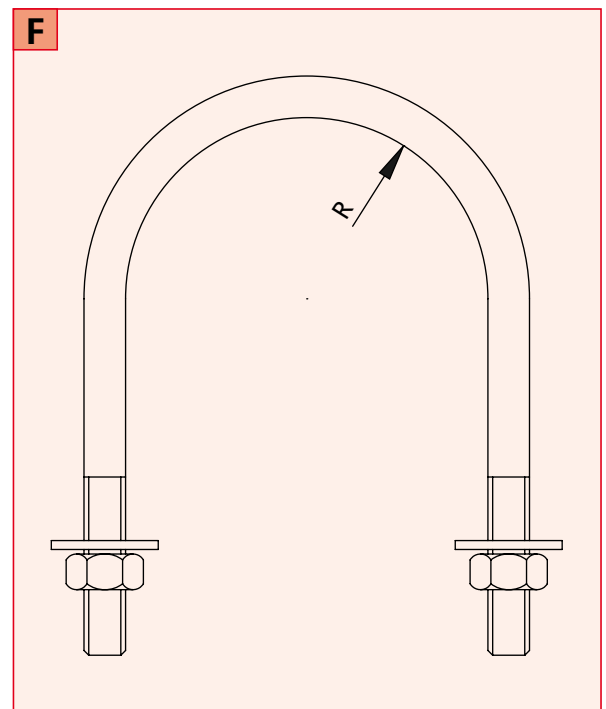

REMARK:

Due to the development of the national and international specifications and of the technology, the above technical characteristics showed on this bulletin can be considered as binding on our confirmation only.